

3CX PBX APPLIANCE

Unified Communications for small offices

Mobile (Android & IOS) Apps and Web clients

Video Conferencing & Live Chat

Multiple access technologies: Telco, SIP, WebRTC



3CX
DISTRIBUTOR

wanderbox

UC&C for small businesses

Copyright © 2007-2020 Far South Networks (Pty) Ltd
www.farsouthnet.com

Brought to you by
Far South Networks



farsouth
networks

Features

Desk mount unit

PBX capacity:

- 50 Users: IP phone or Analogue phone POTS support
- 32 simultaneous calls (select from 8, 16, 24, 32)

SIP trunks: 32 * G.729a CODEC's (select from 8, 16, 24, 32)

Telephony hardware:

- 2 or 4 Analogue (FXS or FXO)
- 2 or 4 Basic Rate ISDN (TE or NT mode)
- 1 Primary Rate ISDN (TE or NT mode)

WAN ports:

- Ethernet
- LTE (cat 4 or 6)

LAN:

- Ethernet, USB2.0 (OTG)
- WiFi Access Point or Client

Network Protocols and Services: PPP, IPv4, HTTPs

Routing: Static, DHCP

IP phone support: Auto-provisioning for Yealink, Poly, snom, Fanvil, Grandstream, Htek

3CX PBX license packages: Standard, Professional and Enterprise

3CX Web-based GUI: User friendly, install and configuration “wizard”

Mobile office tool kit:

- Unified Comms: Voicemail to Email, Fax to Email, Presence, Directory, IM
- Mobile app: IOS and Android
- Web based Video Conferencing
- Digital Assistant & Auto-Attendant
- Click2Call

TMS support: MAN3000 and others

ICASA type approval: TE-2016/068

ORDERING INFORMATION



Part Number Generator

The Wanderbox is modular, with the ordering code made up as follows.

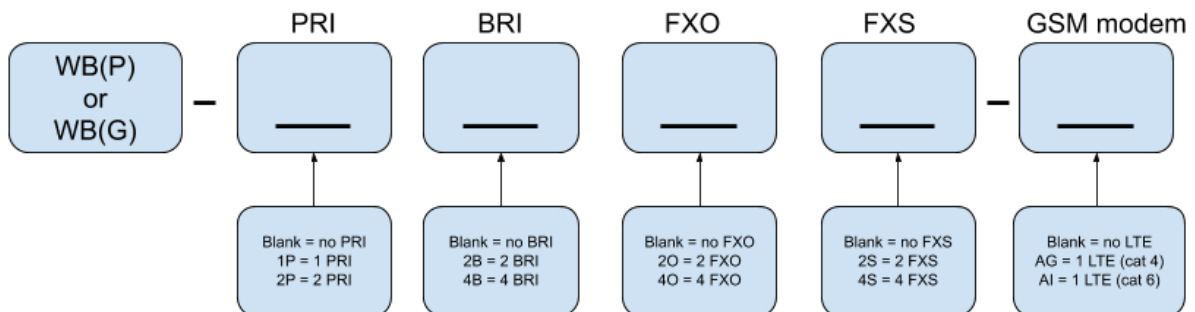

Note:

WB(P) defines the 3CX PBX feature set support

PRI, FXS, FXO, WiFi interface technical specifications within the Wanderbox “Quick Start” and “Installation Guide”

Example part number variants (other options are available)

WB(P)-SX	IP PBX (IP only), 2 Ethernet
WB(P)-2O2S	SIP Gateway with support for 2 FXO, 2 FXS (incl 2FXO<-> 2FXS by-pass), 2 Ethernet
WB(P)-4O	IP PBX with support for 4 FXO, 2 Ethernet
WB(P)-4S	IP PBX, with support for 4 FXS, 2 Ethernet
WB(P)-IP	IP PBX with support for 1 PRI, 4 Ethernet
WB(P)-SX-AG	IP PBX with support for 2 Ethernet, LTE (cat 4)
WB(P)-SX-AI	SIP Gateway with support for 1 Ethernet, LTE (cat 6)

Technical Specifications

Host Processing Platform				
CPU	ARM Cortex-A53, Quad Core, 1.6GHz			
Memory	2GB DDR3 RAM			
Storage	8GB NAND Flash, 32GB solid state storage			
I/O Ports	USB 2.0 (1 * OTG / Host, 1 * UART)			
WAN ports	IEEE802.11b/g/n, Bluetooth, 10/100/1000Base-Tx (RJ45), (optional) 3G/LTE			
Operating System	Debian 10 (Buster)			
Telephony Interfaces (per unit)				
	Primary Rate	Basic Rate	Analog (FXS)	Analog (FXO)
Voice Ports	30 (E1)	0, 4	0, 2, 4	0, 2, 4
	Note: Telephony port expansion supported via connection of Comma iTA units			
Physical	RJ-45	4 x RJ-45	RJ-11	RJ-11
Electrical	E1/G.703 120Ω T1/G.703 100Ω	S/T TE or S/T NT (software selection)	Zone dependent, software programmable DC and AC characteristics. Balanced sinusoidal ringing (3 REN)	Zone dependent, software programmable impedance matching.
Protection	Power cross Inter-building	-	Power cross Inter-building	Power cross Inter-building
Conformance	TBR 4	TBR3		TE-001 (Country- dependent)
Voice Features				
Echo Cancellation	Hardware based G.165 type adaptive echo cancellation per channel Up to 32 channels at 16 ms or 32 ms Up to 16 channels at 64 ms			
Hardware Codecs	-	-	G.711 A-law or μ-law	G.711 A-law or μ-law
Software Codecs	G.711, OPUS, GSM, G.729A			
Fax and Modem	Packet-network synchronization and G.711 provide transparent fax/modem support			
Signaling				
Signaling System	ISDN PRI - ETSI ISDN PRI - NI-2	ISDN BRI – ETSI ISDN BRI – NI- 2	Loop-start DTMF	Loop-start DTMF
Other Features	Configurable network clock synchronization	Configurable network clock synchronization	Caller ID transmission Hook flash Distinctive ring	Caller ID reception
Packet Interfaces				
VoIP	SIP + RTP			

Technical Specifications

RF interfaces (FMC)		
	LTE category 6 (Advanced)	LTE category 4
Antenna Geometry	Dual Rx diversity	Dual Rx diversity
Antenna connector	2 * SMA(F)	2 * SMA(F)
Antenna gain (Omni-850)	2.5dBi	2.5dBi
Frequency range	690MHz – 2700MHz	690MHz – 2700MHz
Polarisation	Linear Vertical	Linear Vertical
SIM slot	Micro SIM	Micro SIM
GSM Frequencies	900 / 1800MHz	900 / 1800MHz
WCDMA bands	1, 3, 5, 8	1, 5, 8
LTE bands	1, 3, 5, 7, 8, 20, 26, 28, 38, 40, 41	1, 3, 5, 7, 8, 20, 38, 40, 41
Carrier Aggregation	2	Non
FDD	50Mbps (UL), 300Mbps (DL)	50Mbps (UL), 150Mbps (DL)
TDD	28Mbps (UL), 266Mbps (DL)	35Mbps (UL), 130Mbps (DL)
GSM	LTE cat 6, WCDMA 3GPP DC-HSDPA	LTE cat 4, WCDMA 3GPP DC-HSPA+
Modulation	QPSK, 16-QAM, 64-QAM	QPSK, 16-QAM, 64-QAM
Approvals	ICASA pending (Quectel EP06E – mPCIe)	ICASA TA-2017/2652 (Quectel EC25E – mPCIe)
Administration		
Management	Web based GUI, including platform backup and restore	
Logging	Log (with configurable levels)	
Field upgrade	Application and firmware remote update from hosted repository	
Physical Characteristics		
Power	12VDC, 2.5A via external AC/DC adapter (supplied)	
Environmental	0°C - 45°C	
Dimensions	127mm x 130mm x 25mm	
Mounting	Desktop	
Certification		
Safety	IEC 60950	
EMC	CISPR22 Class B	
Other	TBR4, TBR3, ICASA TE-001 (South Africa)	

3CX PBX Shortlist Feature Sets

Core PBX Features	STD	PRO	ENT
Extensions	Unlimited	Unlimited	Unlimited
SIP Trunks / Gateways Support	•	•	•
Call Routing by DID & CID (DDI)	•	•	•
Extensive Codec Support	•	•	•
Receive Voice Mail via Email	•	•	•
Calling Line Identification Presentation (CLIP)	•	•	•
Call Transfers (Blind & Attendant)	•	•	•
Calling Line Identification Restriction (CLIR)	•	•	•
Call Forward on Busy (CFB)	•	•	•
Call Forward on No Answer (CFU)	•	•	•
Hold (CW) incl. Custom Music on Hold	•	•	•
Intercom / Paging / PA Announcements	•	•	•
Call Parking / Pickup	•	•	•
Busy Lamp Field (BLF)	•	•	•
Real Time System Status	•	•	•
Easy Backup and Restore (incl. Scheduled Backup)	•	•	•
3CX SBC Connectivity	•	•	•
Voicemail	•	•	•
Voicemail Transcription		•	•
Custom FQDN		•	•
Custom SMTP Server		•	•

Office Productivity	STD	PRO	ENT
Auto Attendant / Digital Receptionist	•	•	•
Ring Extension & Mobile Simultaneously	•	•	•
Integrated Fax Server (Central and per User)	•	•	•
Supported SIP Phones Integration	•	•	•
Manage IP Phones Network Wide	•	•	•
Automatic Plug & Play Phone Provisioning	•	•	•
3CX Apps: Windows and Web Client, iOS, Android	•	•	•
Directory (Company & Private Phonebook)	•	•	•
Sync with Office 365 (Users' Phonebook)		•	•
Call Query against DB & CRM		•	•
Hotel PBX Features incl. Fidelio Certified and Mitel Compatible		•	•
Web Conference Dial-In	25 Participants*	100 Participants*	250 Participants*

3CX PBX Shortlist Feature Sets

Call Center Features	STD	PRO	ENT
Call Logging	•	•	•
Click2Call/Talk/Meet Browser Extension	•	•	•
Website Live Chat and Talk	•	•	•
Call Queue Group Rights Management		•	•
CRM Integration		•	•
Sync with Office 365 (Azure AD)		•	•
Call Queuing		•	•
Real Time Statistics & Monitoring		•	•
Supervisor Agent Status Override		•	•
SLA Alerting		•	•
Switchboard		•	•
Wallboard		•	•
Callback		•	•
Call & Queue Reporting		•	•
Call Recording Transcription and Search		•	•
Barge In / Listen In / Whisper		•	•
See Group Recordings		•	•

3CX PBX APPLIANCE

Secure Business Communications.
Any device. Any place.



FOR MORE INFORMATION

www.farsouthnet.com



+27 21 700 8260

3CX
DISTRIBUTOR

Copyright © 2007-2020 Far South Networks (Pty) Ltd
www.farsouthnet.com

Brought to you by
Far South Networks



farsouth
networks